

**Ida Lewis Yacht Club vs. J80 Fleet 1
Team Race Regatta
June 28-29, 2014**

Organizing Authority: Winnepesaukee Yacht Club (WYC)

SAILING INSTRUCTIONS

1 RULES

- 1.1 The regatta will be governed by the *rules* as defined in *The Racing Rules of Sailing*, including U.S. prescriptions.
- 1.2 USCG-approved PFDs shall be worn at all times while on the water, except while actively adding or removing clothing. This modifies the preamble to Part 4 and rule 40. PFDs shall be worn outside of all clothing unless team identification bibs are issued. Only the Race Committee or Protest Committee may protest for a breach of this Sailing Instruction. This changes rule 60.1(a).
- 1.3 No boat shall discharge trash of any kind into Lake Winnepesaukee. Any boat observed breaking this rule is subject to protest only by the Race Committee or Protest Committee. The penalty for a breach of this rule, which may include disqualification from a race, is at the discretion of the Protest Committee. This changes rules 60.1(a) and 64.1(a).

2 NOTICES TO COMPETITORS

Notices to competitors will be posted on the Official Notice Board located at WYC at 45 Dockham Shore Rd, Gilford, NH 03249

3 CHANGES IN THE SAILING INSTRUCTIONS

Any change in the Sailing Instructions will be approved by the Race Committee and posted immediately after the Participants' Meeting on the day it will take effect, except that changes made to SI 8 may be made verbally and will be effective immediately, in which case flag A will be flown from the Signal Boat.

4 SIGNALS MADE ASHORE

- 4.1 Signals made ashore will be displayed at WYC.
- 4.2 When a Postponement (flag AP) is displayed ashore, the warning signal will be made not less than 45 minutes after flag AP is lowered.

5 BOATS PROVIDED BY THE ORGANIZING AUTHORITY (OA)

- 5.1 J-80 one design boats will be provided by the J-80 Fleet 1 for competing teams. The boats have been equalized in performance potential to the extent possible and organized into fleets. An alternate boat may be substituted in case of a breakdown. Claims regarding the performance of the boats will not be grounds for a redress request. This changes rule 62.1(a).
- 5.2 To keep the boats as equal as possible, the following limitations shall apply to all competitors:

- The boats shall be sailed with the rigging and fittings as supplied. Replacement of broken or damaged gear may only be made with gear sanctioned by the OA. Electrical or rigging tape may be used to help prevent gear from snagging.
- Halyards shall not be unroveed.
- Standing rigging shall be set to a standard setting prior to the start of the regatta and shall not be adjusted nor tensions altered for the duration of the event except by the OA.
- Mast block placement shall be set prior to the start of the regatta and shall not be altered for the duration of the event except by the OA.
- Only one set of sails shall be used for the duration of the event unless a substitution is authorized by the OA.
- Every effort should be made to avoid damage to hulls, rigging and sails. As stated in the Notice of Race, all skippers will be required to provide a \$500 damage deposit prior to the start of racing.
- Competitors are responsible for inspecting their assigned boats each day for possible breakdowns and missing equipment. Discrepancies must be reported immediately.
- All equipment shall be used as supplied and no changes, additions or subtractions shall be made other than those permitted by the Sailing Instructions or the Organizing Authority.

6 SCHEDULE

- 6.1 A meeting of participants will be held at 0930 on Saturday, June 28, at the WYC.
- 6.2 No warning signal will be made after 1200 on Sunday.

7 REGATTA FORMAT

- 7.1 The regatta will consist of a series of as many races as are reasonably practicable given the sailing conditions and other considerations, subject to the discretion of the OA. The team with the most points at the end of racing on Sunday shall be the winner of the regatta. If the teams are tied in points, the team that won the last completed race shall be the winner of the regatta. This changes D4.2. One race will constitute a regatta. The Organizing Authority, in consultation with the team captains of both WYC and ILYC as well as the Protest Committee, may terminate or alter the format in progress, or make such other arrangements as may be necessary to complete the event.

8 FLEET DESIGNATION

Each visiting team will be assigned boats at the Saturday morning Participants' Meeting for the Regatta. Designations will then be posted on the Official Notice Board as an amendment to these instructions.

9 RACING AREA

The racing area will be on Lake Winnepesaukee. The location of the rendezvous and time of the warning signal for the first race will be announced at the Participants' Meeting.

10 COURSE

10.1 The Course flag will be displayed at or before the warning signal.

10.2 The Race Committee may change a leg of the course that begins at a rounding mark by changing the position of the next mark or the finishing line, but no mark shall be moved when any boat is on the leg that it terminates. Subsequent legs may be changed to maintain the course configuration. There will be no visual or audible signals for a course change. This changes rule 33.

10.3 Races may not be shortened. This changes rule 32 and Race Signal flag S.

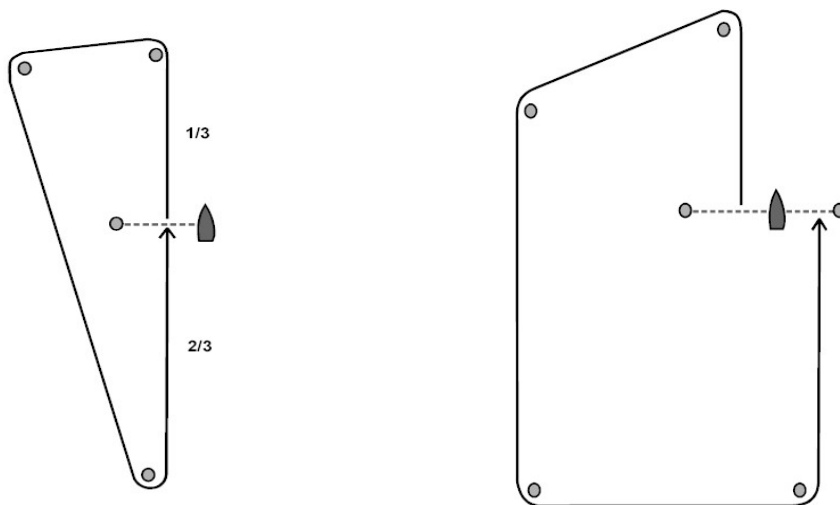

"T" - MODIFIED TRIANGLE

"V" - BOX COURSE

11 MARKS

All marks will be inflatable marks.

12 START AND FINISH

12.1 The start and finish lines will be between a staff displaying an orange flag on the Signal Boat and an inflatable mark. The Signal Boat may deploy a "Keep Off" buoy from her stern.

12.2 The signals for starting the races will be in accordance with RRS rule 26.

13 RECALLS

13.1 Individual recalls will be made in accordance with RRS rule 29.2, modified in that the Individual Recall flag (flag X) will be displayed but not later than one minute following the start.

13.2 When a General Recall is signaled, the First Substitute will be accompanied by repeated short sound signals. This changes rule 29.2 and Race Signal First Substitute.

14 TIME LIMIT

The time limit will be 30 minutes for the first boat to sail the course and finish. Any boat not finishing within 15 minutes of the first boat to finish or within the time limit, whichever is

later, will be scored points equal to the number of boats entitled to *race*. This changes rules 35 and D3.

15 PROTESTS and ACKNOWLEDGEMENT of BREACHES

15.1 Appendix D, rule D2 applies for all *protests*.

15.2 On the water protests shall be judged by designated umpires.

15.3 The Protest Committee may require that protests be heard on the water directly after the parties involved have finished the race. The “three-minute justice” system may be used, which changes rule 63.2 regarding time for preparation for the hearing, and rule 63.6 regarding the calling of witnesses.

16 SCORING

Scoring will be per Appendix D

17 SPINNAKERS

Spinnakers will not be used during the racing.

18 NOTES

18.1 All times herein are Eastern Daylight Time.

18.2 Except in the case of an emergency, no electronic communication shall take place between or among team members.

18.3 Government buoys, when not designated as having to be observed, or not specified as marks of the course, have no required side except for safe navigation.

19 SAFETY

In accordance with rule 4, the responsibility for a boat’s decision to participate in a race or to continue racing is hers alone. The responsibility for the safety of the boat and each competitor lies solely with each individual and not with the WYC or J80 Fleet 1.

20 PRIZES

Winning team name will placed on half hull.